

NEW

Solid Centering Endmill

CES302

- ✓ Excellent chip emission
- ✓ Side Cutting Edge for Side milling
- ✓ Superior wear resistance by TiAlN coating
- ✓ Suitable for up to HRC50 hardness material

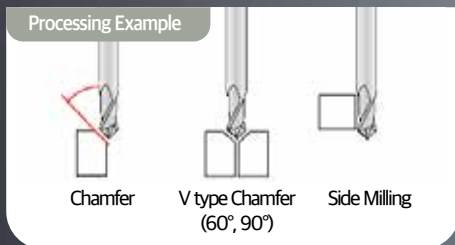

RECOMMENDED CUTTING CONDITIONS

Workpiece	Carbon steels, Alloy steels						Stainless steels, Titanium		Aluminum	
Hardness	~HRC20		HRC20~ HRC30		HRC30~ HRC40					
Tensile strength	500~800N/mm ²		800~1000N/mm ²		1000~1300N/mm ²					
Diameter	RPM	FEED	RPM	FEED	RPM	FEED	RPM	FEED	RPM	FEED
3	5,900	60	4,000	30	3,300	25	2,400	20	14,000	220
4	4,800	60	3,300	30	2,800	25	2,000	20	11,800	230
5	3,800	60	2,500	30	2,200	25	1,760	20	9,500	240
6	3,000	60	2,000	30	1,800	30	1,400	20	7,700	250
8	2,300	65	1,540	35	1,300	35	1,100	20	5,800	260
10	2,000	65	1,300	35	1,200	35	1,000	20	5,000	260
12	1,760	65	1,000	40	1,000	35	540	20	4,400	260
16	1,400	65	900	40	770	35	660	25	3,300	270
20	1,100	65	700	40	600	35	440	25	2,600	270

※ Increase and reduce depending on the condition of the equipment, cutting oil, etc. (adjust within the first 15%)

CES302

60° & 90° SOLID CENTERING ENDMILL

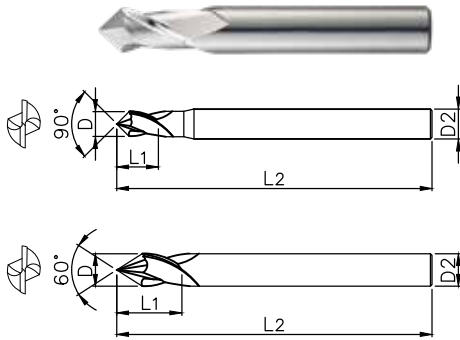

-Multi-functional Carbide Endmill which can simultaneously process centering, chamfering and side cutting.

-Suitable for various workpieces up to HRc50 such as Mid-hardness steel, pre hardened steel, Cast iron and etc.

NEW

CES302 60°

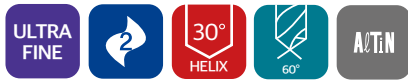

EDP No.		Diameter	Flute length	Overall	Shank Diameter
non coating	coating	D	L1	L2	D2
CES302030-060S3	CES302030-060S3-C	3	6	50	3
CES302040-060S4	CES302040-060S4-C	4	8	50	4
CES302050-060S5	CES30 2050-060S5-C	5	10	50	5
CES302060-060	CES302060-060-C	6	12	60	6
CES302080-060	CES302080-060-C	8	16	70	8
CES302100-060	CES302100-060-C	10	18	70	10
CES302120-060	CES302120-060-C	12	20	75	12

CES302 90°

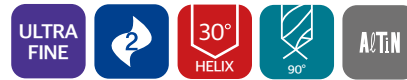

■ Tolerance

Diameter (D)		Shank Diameter
All size	0~-0.05mm	h6

EDP No.		Diameter	Flute length	Overall	Shank Diameter
non coating	coating	D	L1	L2	D2
CES302020S2	CES302020S2-C	2	5	50	3
CES302030	CES302030-C	3	6	50	6
CES302030S3	CES302030S3-C	3	6	50	3
CES302040	CES302040-C	4	8	50	6
CES302040S4	CES302040S4-C	4	8	50	4
CES302050	CES302050-C	5	10	50	6
CES302050S5	CES302050S5-C	5	10	50	5
CES302060	CES302060-C	6	12	60	6
CES302080	CES302080-C	8	16	70	8
CES302100	CES302100-C	10	18	70	10
CES302120	CES302120-C	12	20	75	12
CES302140	CES302140-C	14	24	80	14
CES302160	CES302160-C	16	26	80	16
CES302200	CES302200-C	20	32	100	20

■ Application

Carbon steels ~HB225	Alloy steels HB225~325	pre-hardened Steels HRc30~50	Heat treated steels		Copper	Graphite	Cast Iron ~FCD500	Stainless steels	Aluminum
			SKD61~HRc55	SKD11~HRc55					
●	●	●			●		●		

Head office & Changwon Factory

172, Sahwa-ro, Uichang-gu, Changwon-si, Gyeongsangnam-do, Korea [51389]
TEL. +82-55-286-0905 FAX. +82-55-286-0978

WIDIN USA

1261 Wiley Rd. Unit F., Schaumburg, IL 60173, USA
TEL. +1-847-947-8320 FAX. +1-847-947-8322

WIDIN Viet Nam(OFFICE & FACTORY)

Lot CN5, Hop Thinh Industrial Zone, Hop Thinh Commune, Hiep Hoa District, Bac Giang Province, Viet Nam
TEL. +84-20-4248-4883